

NOTES:

- 1.) SEAM SEALED WITH FLEXIBLE BUTYL RUBBER SEALANT.

CONCENTRIC TAPERED CONCRETE COVER
Ø26" CLEAR OPENING.

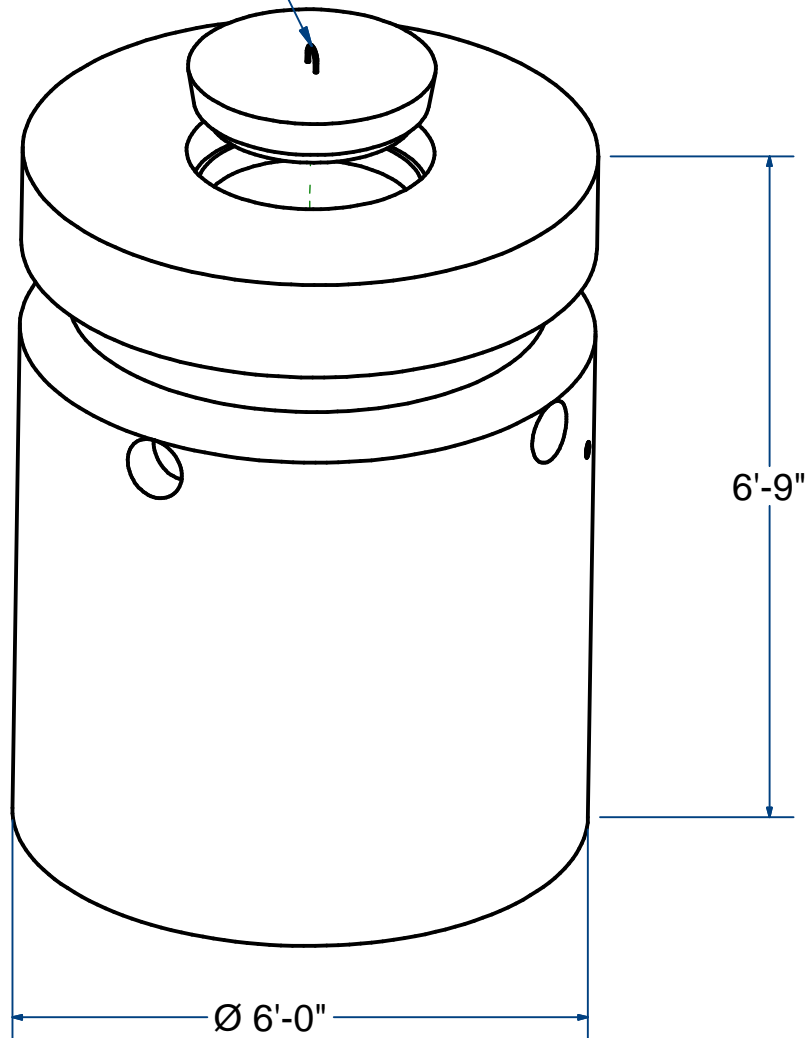

PUMP CHAMBER 5' I.D.

H2O

650 Gallon

ACME-SHOREY

PRECAST CONCRETE PRODUCTS

NOTES:

- 1.) SEAM SEALED WITH FLEXIBLE BUTYL RUBBER SEALANT.
- 2.) OPTIONAL ITEMS:
 - A.) BOOTS.
 - B.) COATING.
 - C.) EXTENDED BASE.
- 3.) STD COVER TAPERS FROM Ø30" TO Ø26".

CONCENTRIC TAPERED CONCRETE COVER
Ø26" CLEAR OPENING.

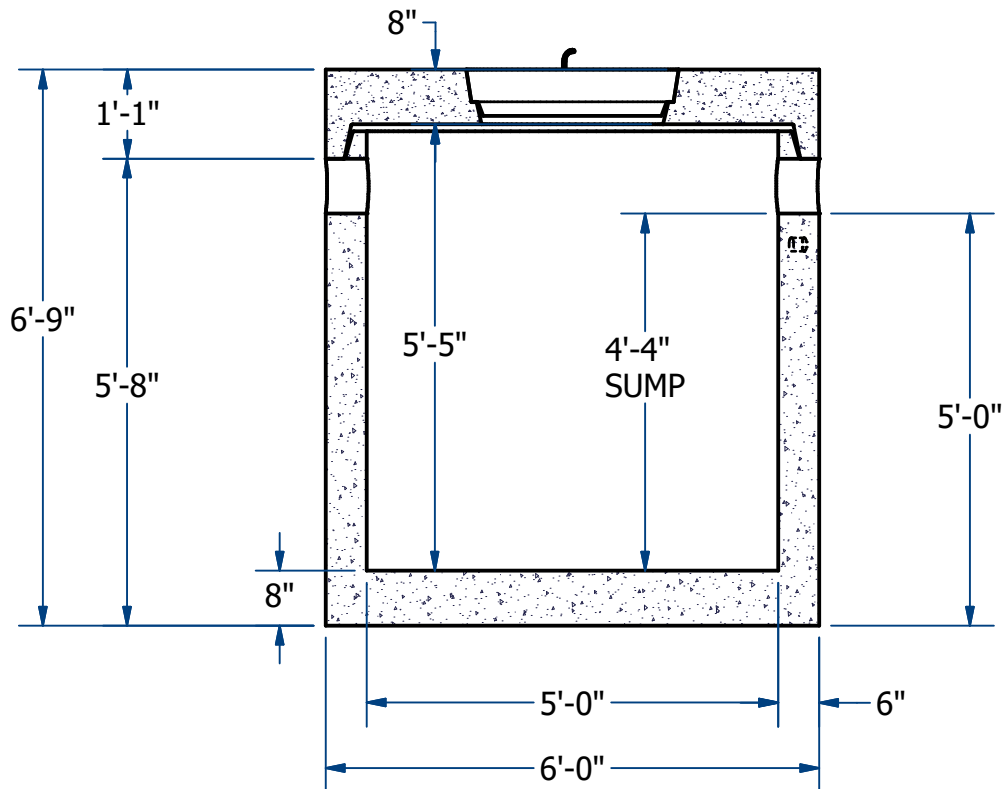
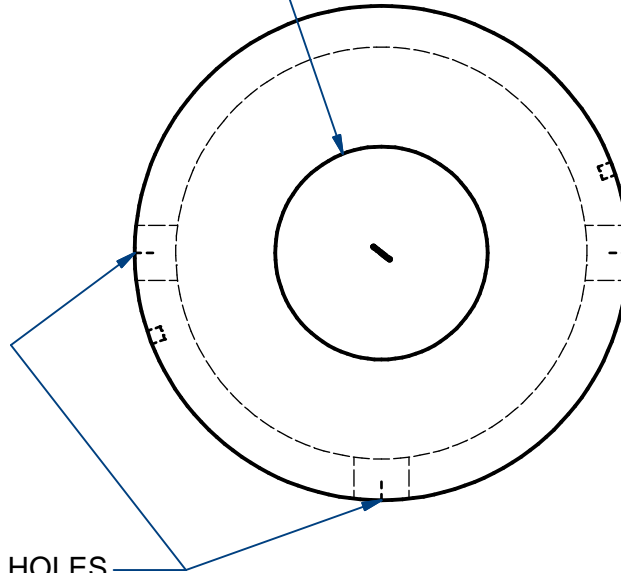

NAME: PUMP CHAMBER, 5'ID, 650 Gallons

H-20

ITEM# PCR5650

Concrete Minimum Strength: 5,000 p.s.i. at 28 days
Steel Reinforcement: ASTM A615, Grade 60
Design Loading: standard units - AASHTO - H20

TOP 2,750 Lbs
BOTTOM 9,400 Lbs

H

DATE: 9-24-2021

Ch 9 Pg 2.2 Sht 2 of 2