

NOTES:

- 1.) SEAM SEALED WITH FLEXIBLE BUTYL RUBBER SEALANT.

CONCENTRIC TAPERED CONCRETE COVER  
Ø26" CLEAR OPENING.

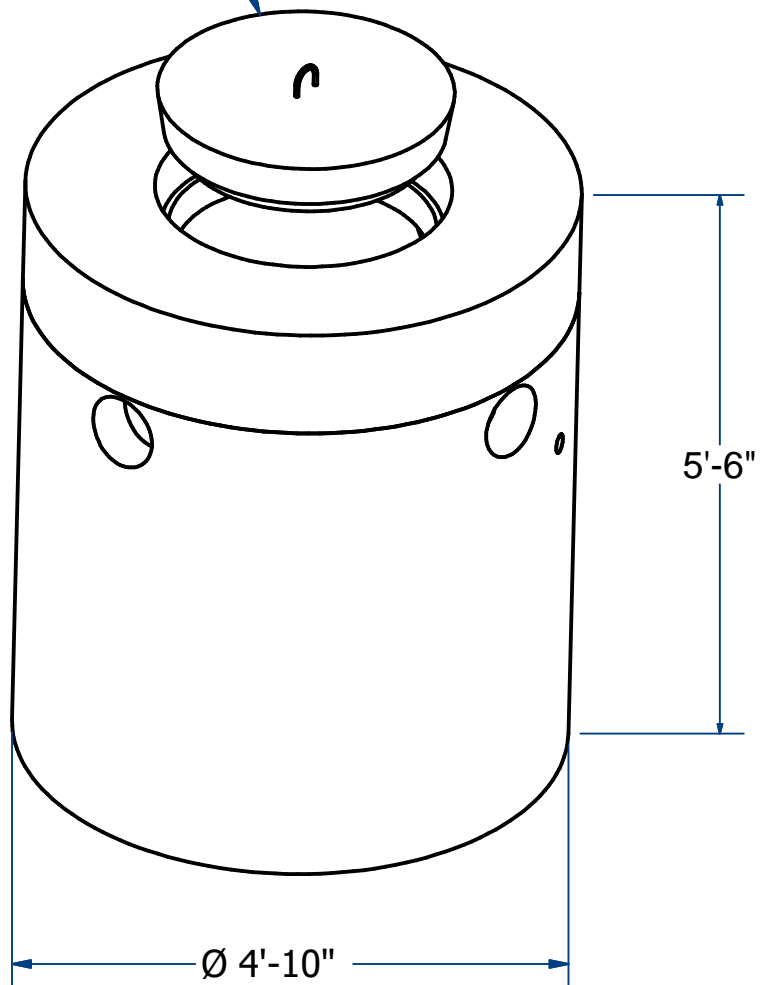

**PUMP CHAMBER 4' I.D.**

H20

335 Gallon

# ACME-SHOREY

PRECAST CONCRETE PRODUCTS

**NOTES:**

- 1.) SEAM SEALED WITH FLEXIBLE BUTYL RUBBER SEALANT.
- 2.) OPTIONAL ITEMS:
  - A.) BOOTS.
  - B.) COATING.
  - C.) EXTENDED BASE.
- 3.) STD COVER TAPERS FROM Ø30" TO Ø26".

CONCENTRIC TAPERED CONCRETE COVER  
Ø26" CLEAR OPENING.

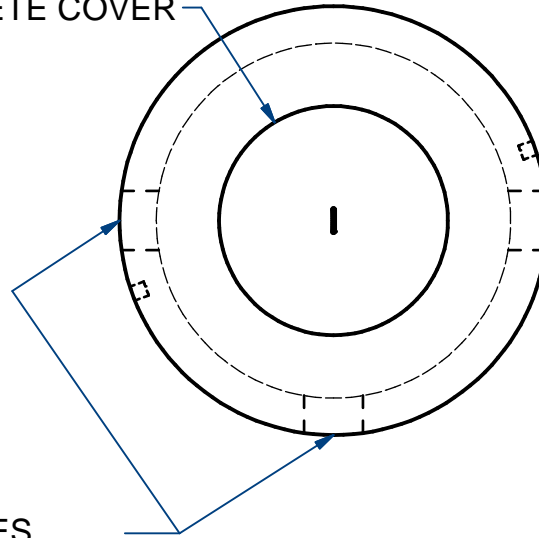

(3) Ø8" HOLES  
@ 3,6,& 9 O'CLOCK

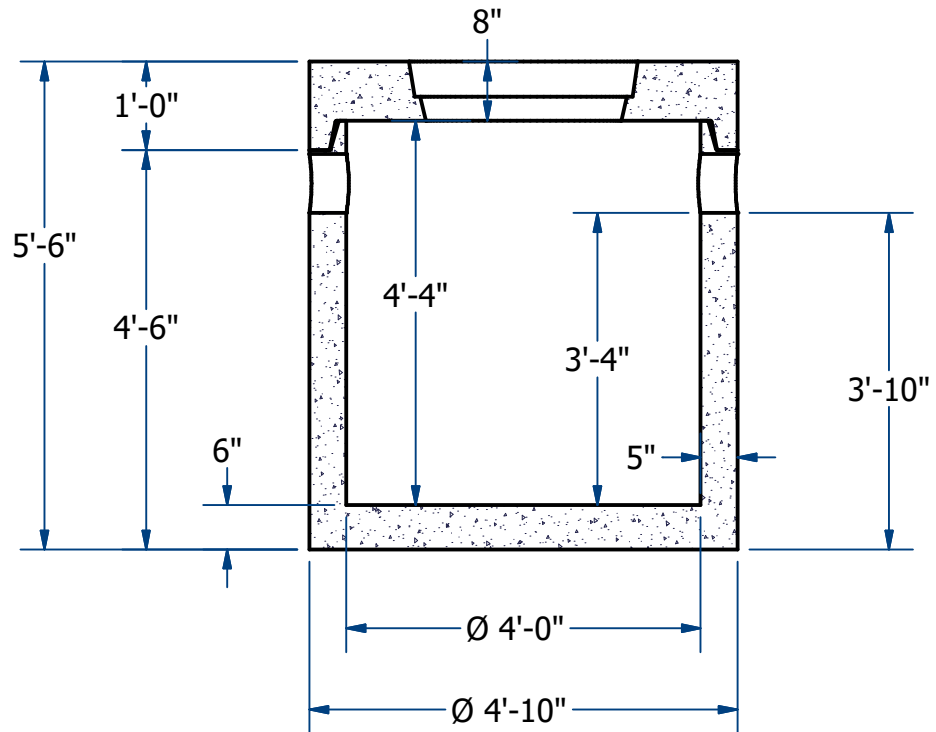

**NAME: PUMP CHAMBER, 4'ID, 335 Gallons**

**H-20**

**ITEM# PCR4335**

Concrete Minimum Strength: 5,000 p.s.i. at 28 days  
Steel Reinforcement: ASTM A615, Grade 60  
Design Loading: standard units - AASHTO - H20

TOP 1,500 Lbs  
BOTTOM 5,200 Lbs

H

DATE: 1-11-23

Ch 9 Pg 1.1 Sht 2 of 2