

NOTES:

- 1.) SEAM SEALED WITH FLEXIBLE BUTYL RUBBER SEALANT.

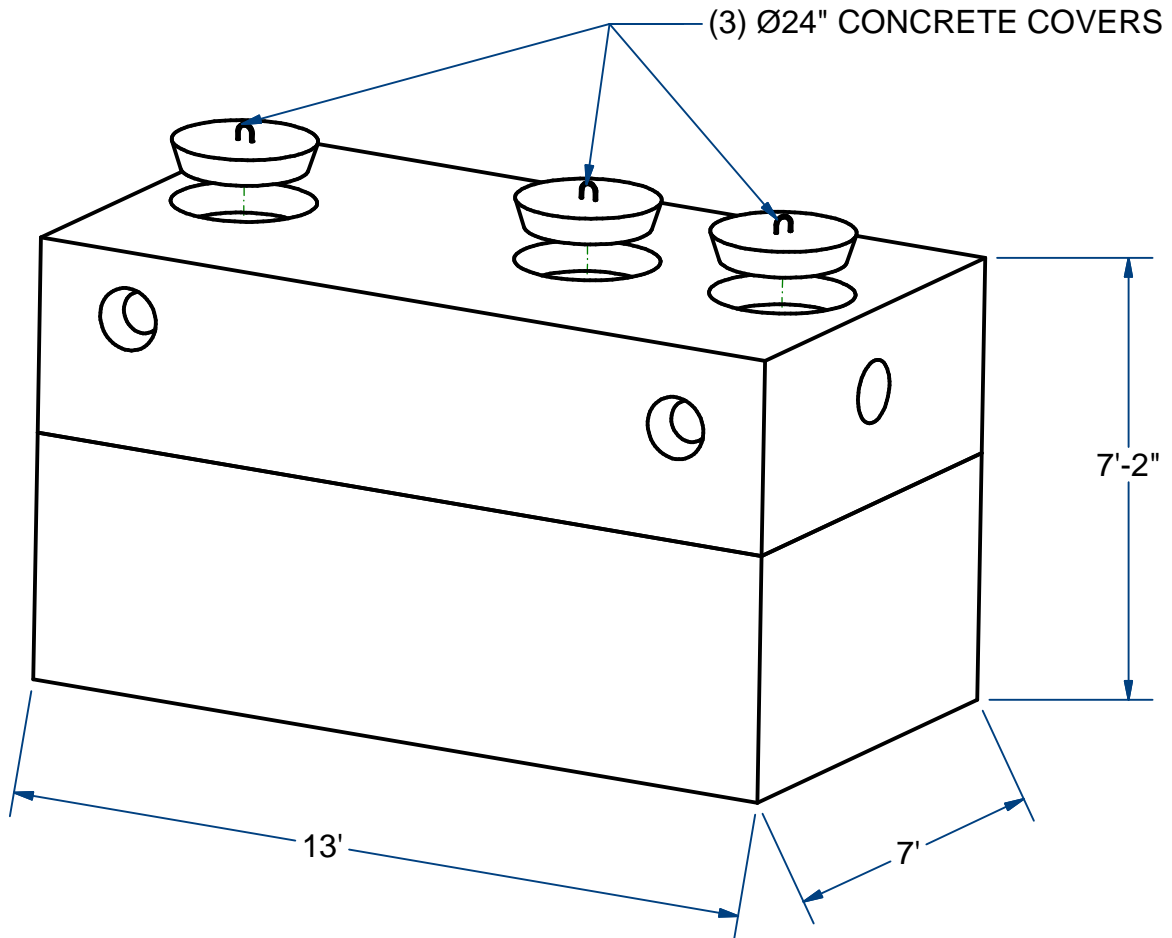

PUMP CHAMBER

H20

2,500 Gallon

ACME-SHOREY

PRECAST CONCRETE PRODUCTS

NOTES:

- 1.) SEAM SEALED WITH FLEXIBLE BUTYL RUBBER SEALANT.

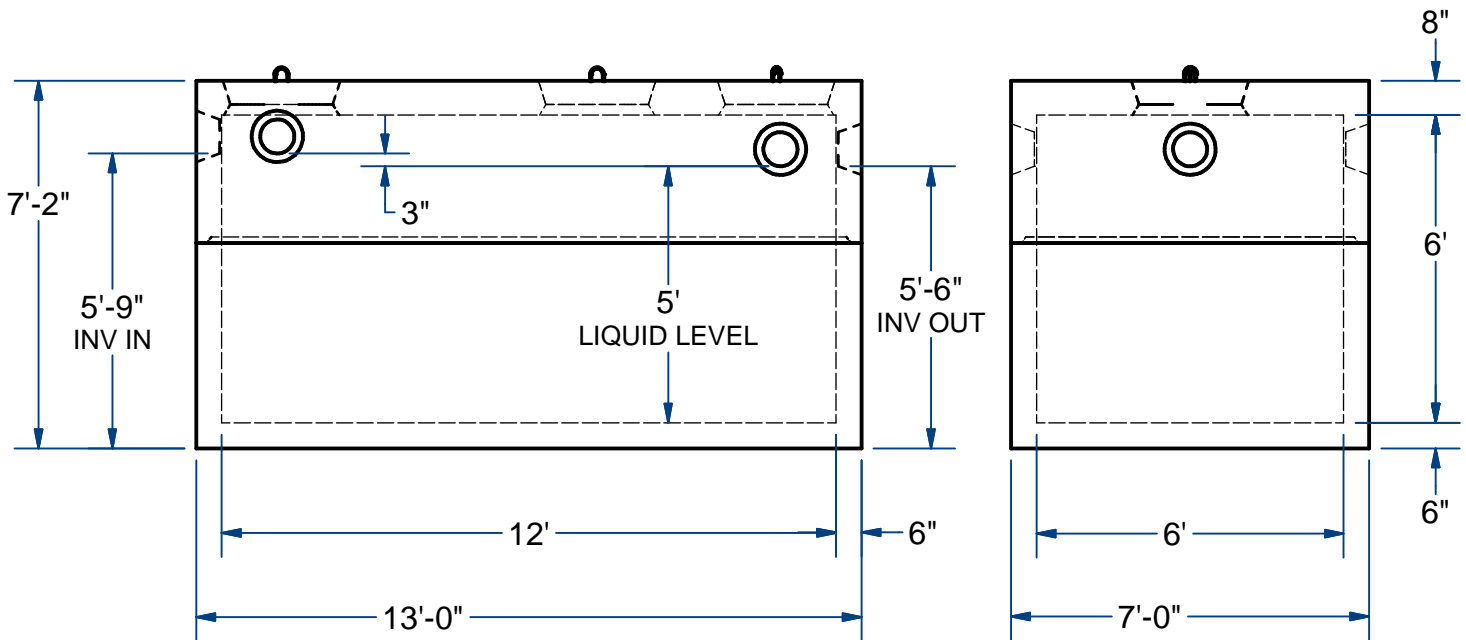
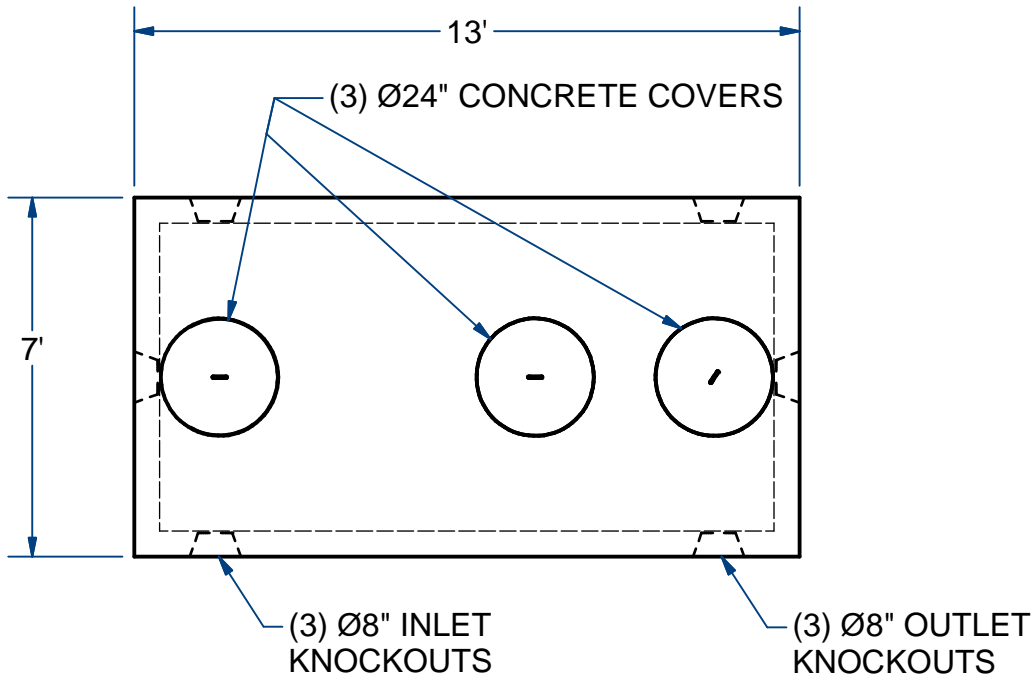

NAME: PUMP CHAMBER, LowPro, 2500 Gallon H-20 ITEM# PC252LP

Concrete Minimum Strength: 5,000 p.s.i. at 28 days
 Steel Reinforcement: ASTM A615, Grade 60
 Design Loading: standard units - AASHTO - H20

TOP 15,800 Lbs
 BOTTOM 18,250 Lbs

C DATE: 5-2-2019
 Ch 9 Pg 10.1 Sht 2 of 2