

# ACME-SHOREY

PRECAST CONCRETE PRODUCTS

WWW.ACMESHOREY.COM

PHONE (508) 548-9607

FAX (508) 548-1664

CARVER, MA  
334 TREMONT STREET

HARWICH, MA  
36 GREAT WESTERN ROAD

## NOTES:

- 1.) SEAM SEALED WITH FLEXIBLE BUTYL RUBBER SEALANT.

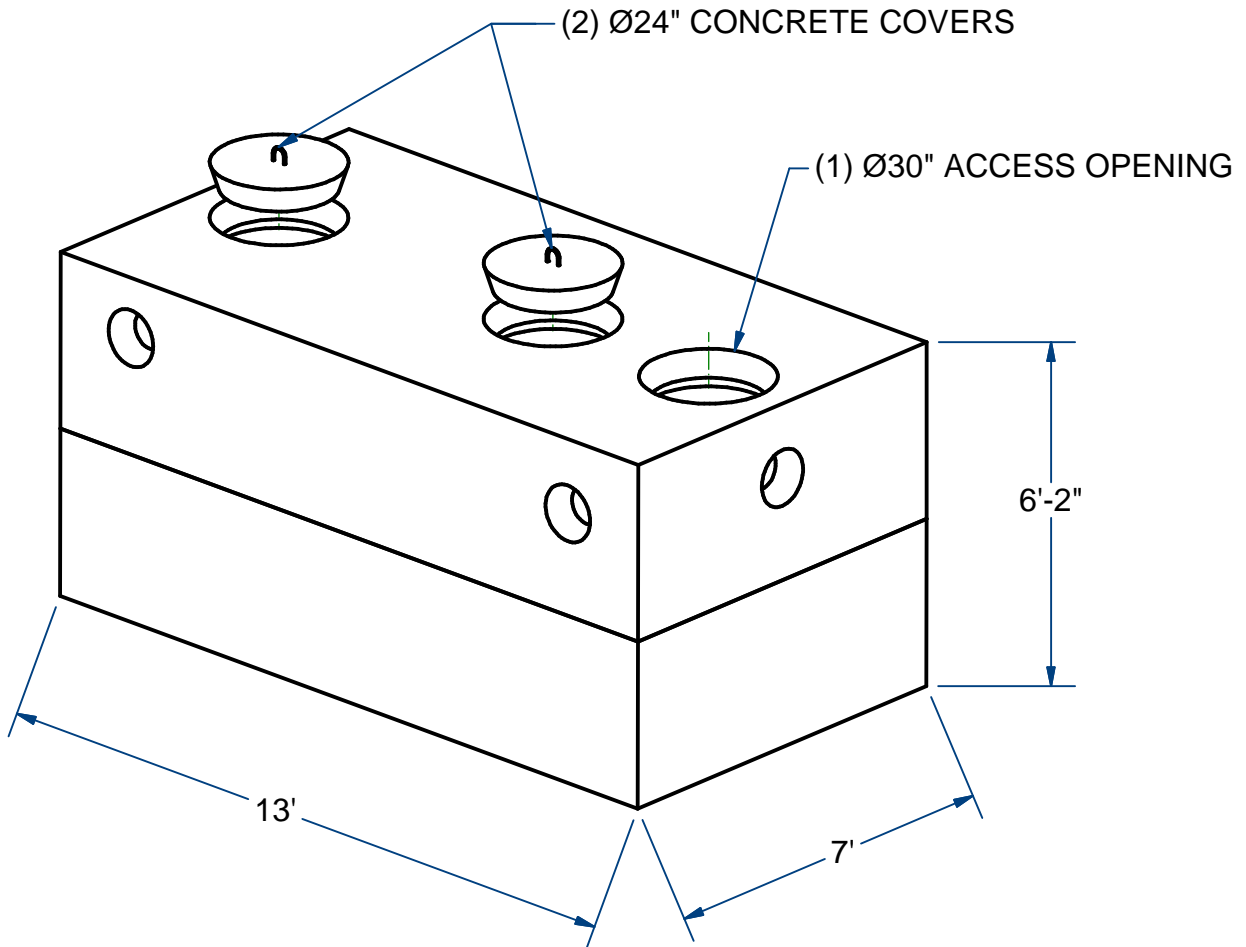

## PUMP CHAMBER

H20

2000 Gallon

ITEM# PC202LP30

Wt. 31,000 Lbs

9 -8.2

Sht 1 of 2

# ACME-SHOREY

PRECAST CONCRETE PRODUCTS

NOTES:

- 1.) SEAM SEALED WITH FLEXIBLE BUTYL RUBBER SEALANT.

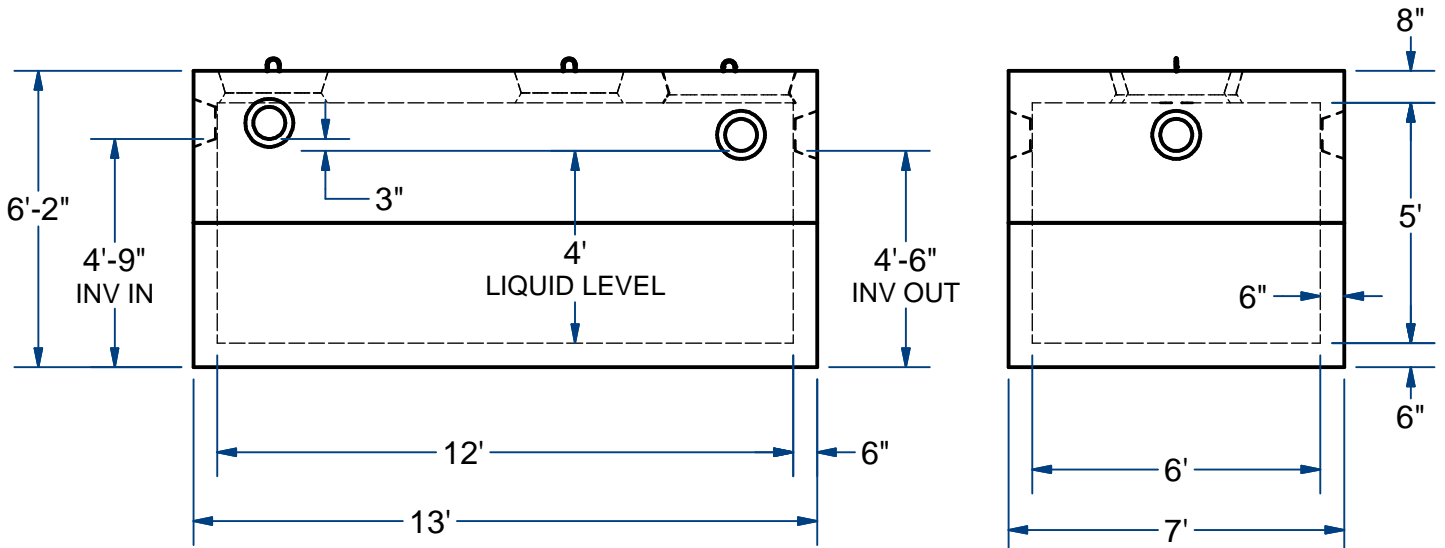
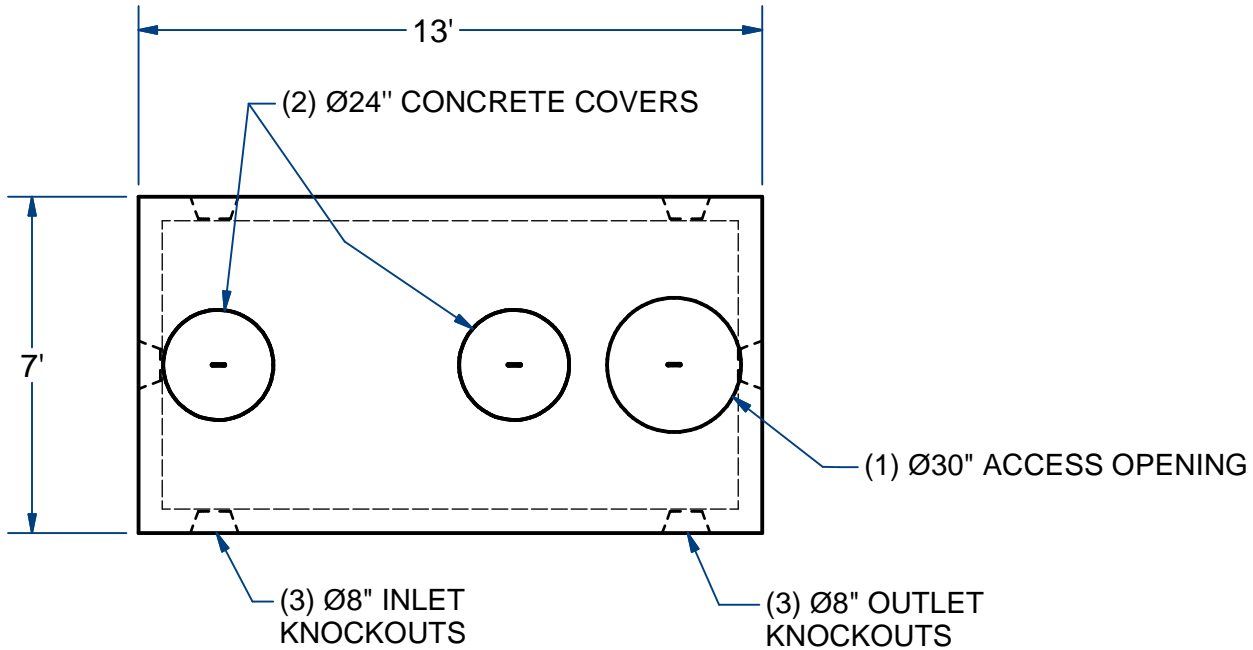

**NAME: PUMP CHAMBER, 2000 Gallon, Low Profile H-20**

**ITEM# PC202LP30**

Concrete Minimum Strength: 5,000 p.s.i. at 28 days  
 Steel Reinforcement: ASTM A615, Grade 60  
 Design Loading: standard units - AASHTO - H20

TOP 15,750 Lbs  
 BOTTOM 15,250 Lbs

C

DATE: 5-2-2019

Ch 9 Pg 8.2 Sht 2 of 2