

ACME-SHOREY

PRECAST CONCRETE PRODUCTS

WWW.ACMESHOREY.COM

PHONE (508) 548-9607

FAX (508) 548-1664

CARVER, MA
334 TREMONT STREET

HARWICH, MA
36 GREAT WESTERN ROAD

NOTES:

- 1.) SEAM SEALED WITH FLEXIBLE BUTYL RUBBER SEALANT.

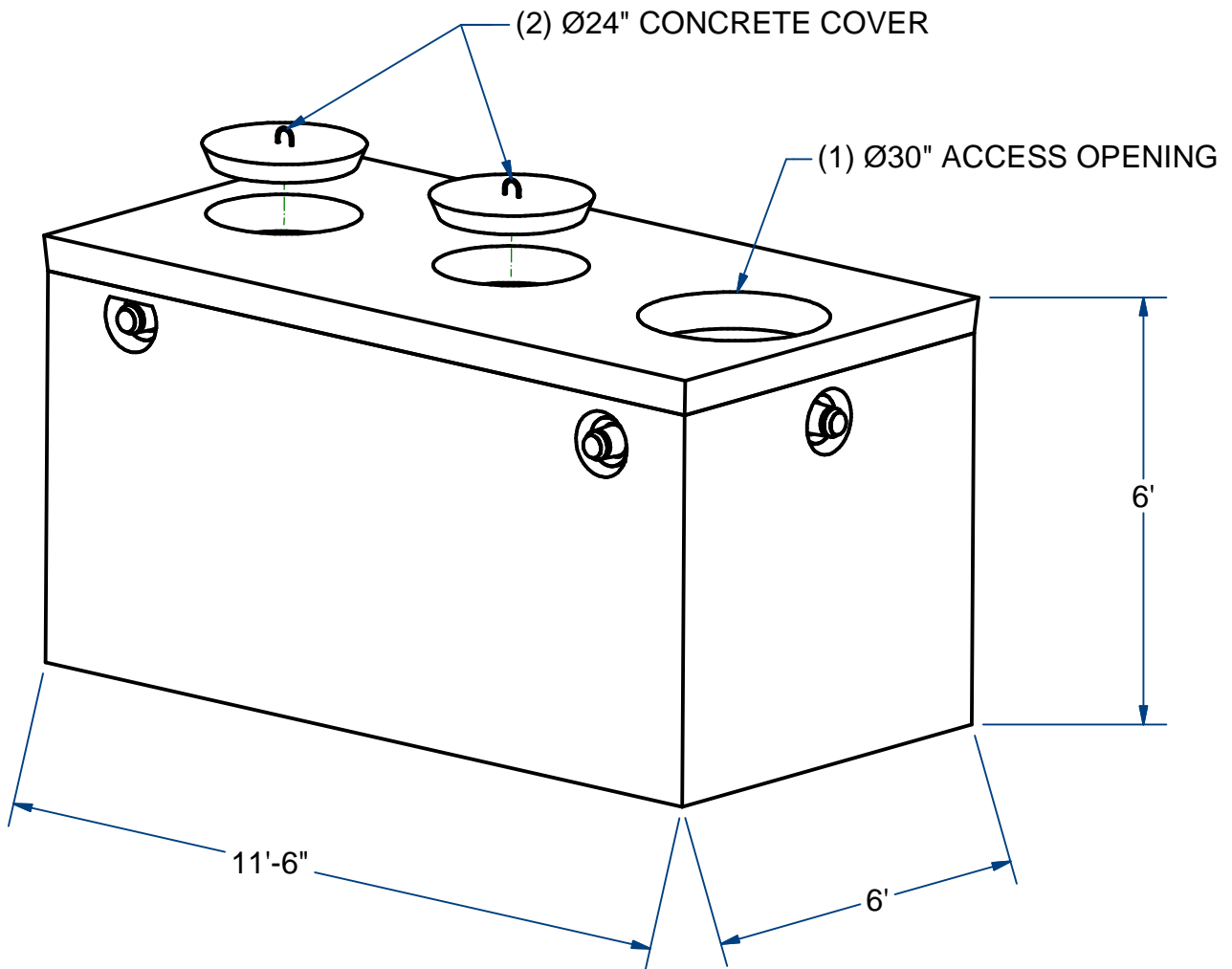

PUMP CHAMBER, MONO, W/BOOTS

H20

1500 Gallon

ITEM# PC152M30-B24

Wt. 23,000 Lbs

9 -7.4

Sht 1 of 2

ACME-SHOREY

PRECAST CONCRETE PRODUCTS

NOTES:

- 1.) SEAM SEALED WITH FLEXIBLE BUTYL RUBBER SEALANT.

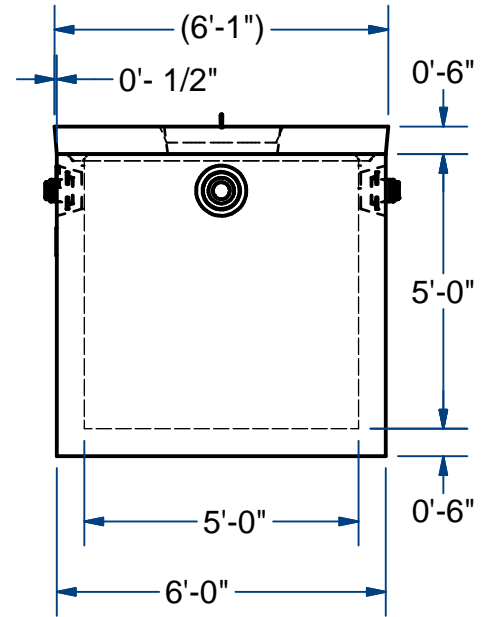
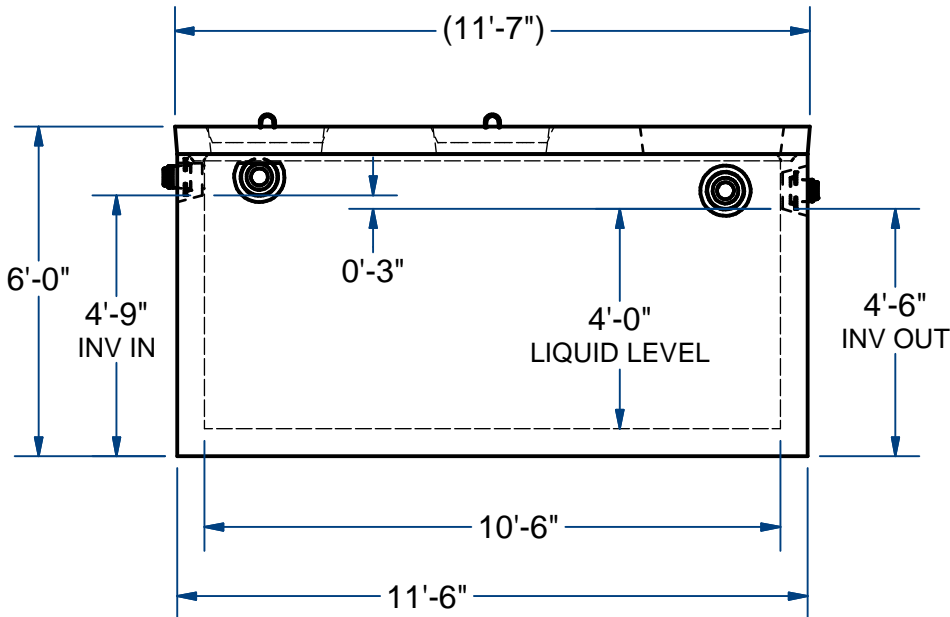
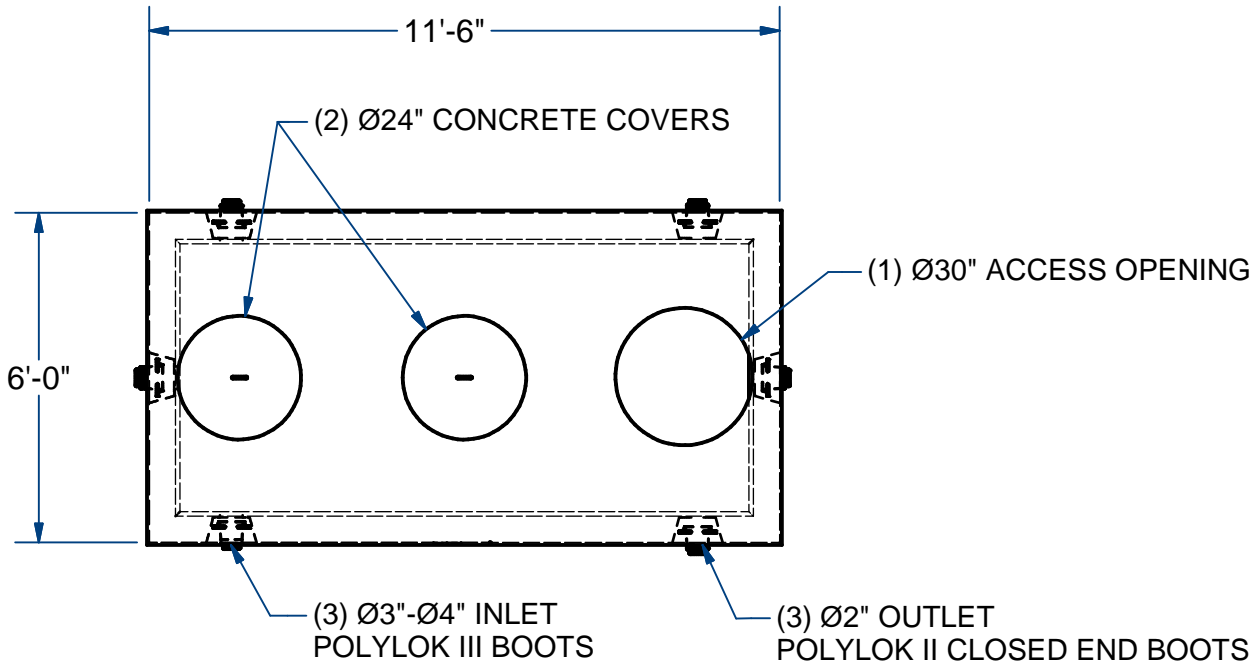

NAME: PUMP CHAMBER , MONO, 1500 Gallon, W/BOOTS H-20

ITEM# PC152M30-B24

Concrete Minimum Strength: 5,000 p.s.i. at 28 days
 Steel Reinforcement: ASTM A615, Grade 60
 Design Loading: standard units - AASHTO - H20

TOP 5,000 Lbs
 BOTTOM 18,000 Lbs

C

DATE: 2-2-2019