

ACME-SHOREY

PRECAST CONCRETE PRODUCTS

WWW.ACME-SHOREY.COM

PHONE (508) 548-9607

FAX (508) 548-1664

CARVER, MA

334 TREMONT STREET

HARWICH, MA

36 GREAT WESTERN ROAD

NOTES:

- 1.) SEAM SEALED WITH FLEXIBLE BUTYL RUBBER SEALANT.

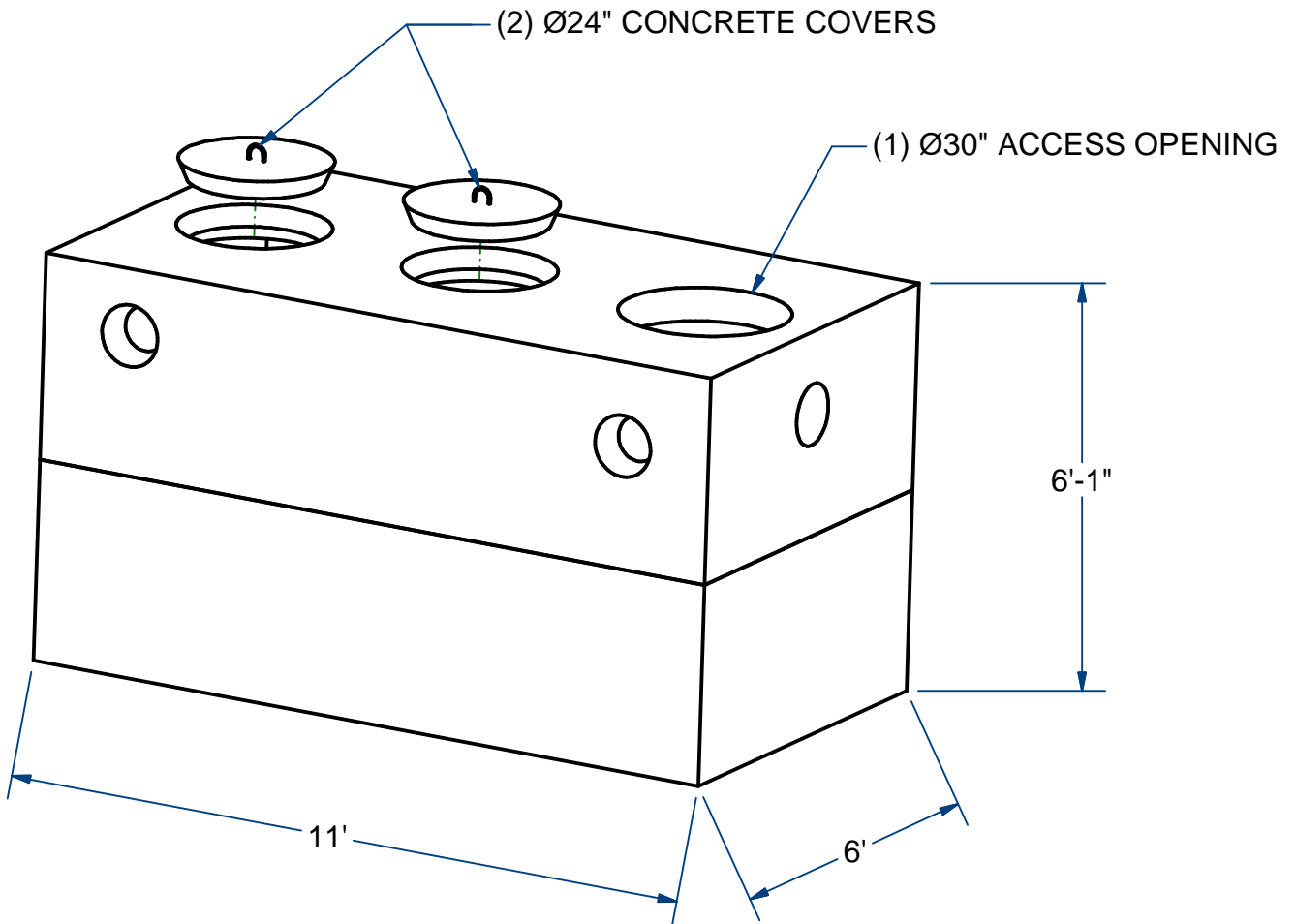

PUMP CHAMBER

H20

1500 Gallon

ITEM# PC15230

Wt. 23,000 Lbs

9 -6.2

Sht 1 of 2

ACME-SHOREY

PRECAST CONCRETE PRODUCTS

NOTES:

- 1.) SEAM SEALED WITH FLEXIBLE BUTYL RUBBER SEALANT.

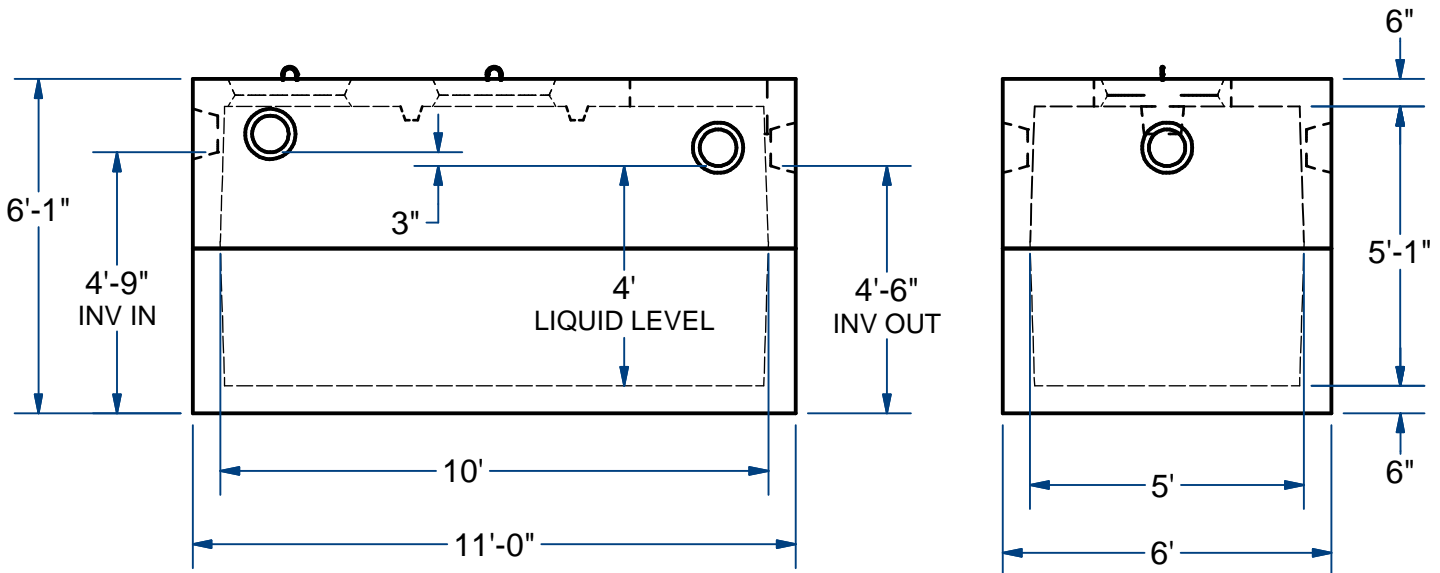
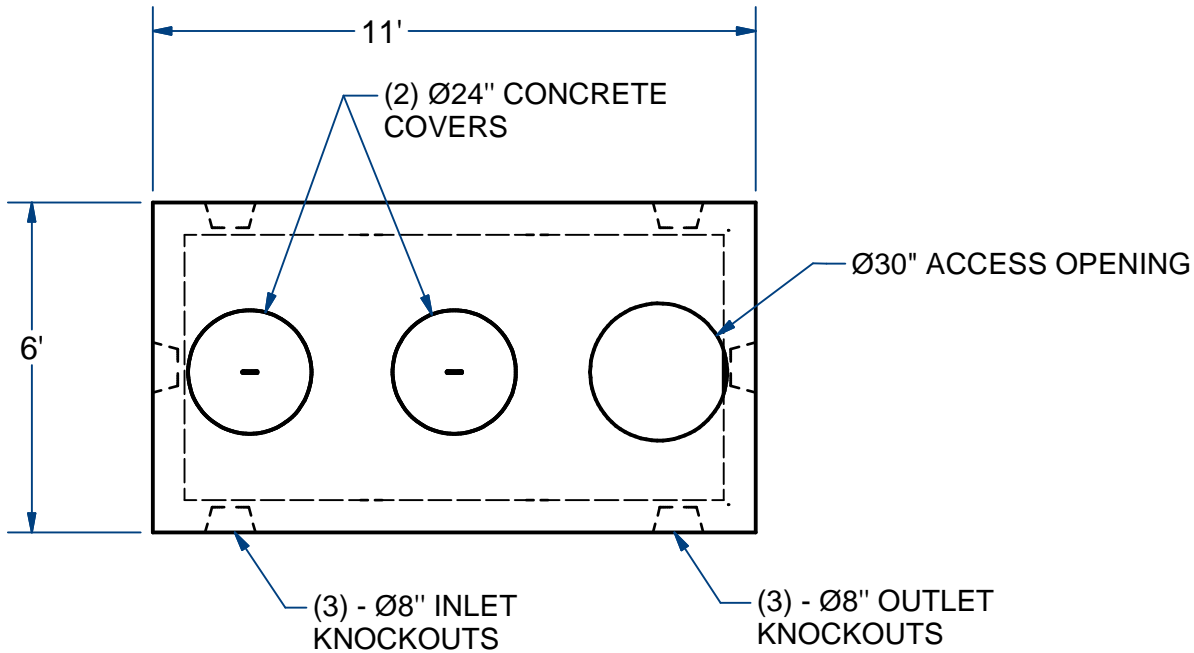

NAME: PUMP CHAMBER ,1500 Gallon

H-20

ITEM# PC15230

Concrete Minimum Strength: 5,000 p.s.i. at 28 days
 Steel Reinforcement: ASTM A615, Grade 60
 Design Loading: standard units - AASHTO - H20

TOP 11,000 Lbs
 BOTTOM 12,000 Lbs

CH

DATE: 3-14-19

Ch 9 Pg 6.2 Sht 2 of 2