

NOTES:
1.) SEAM SEALED WITH FLEXIBLE BUTYL RUBBER SEALANT.

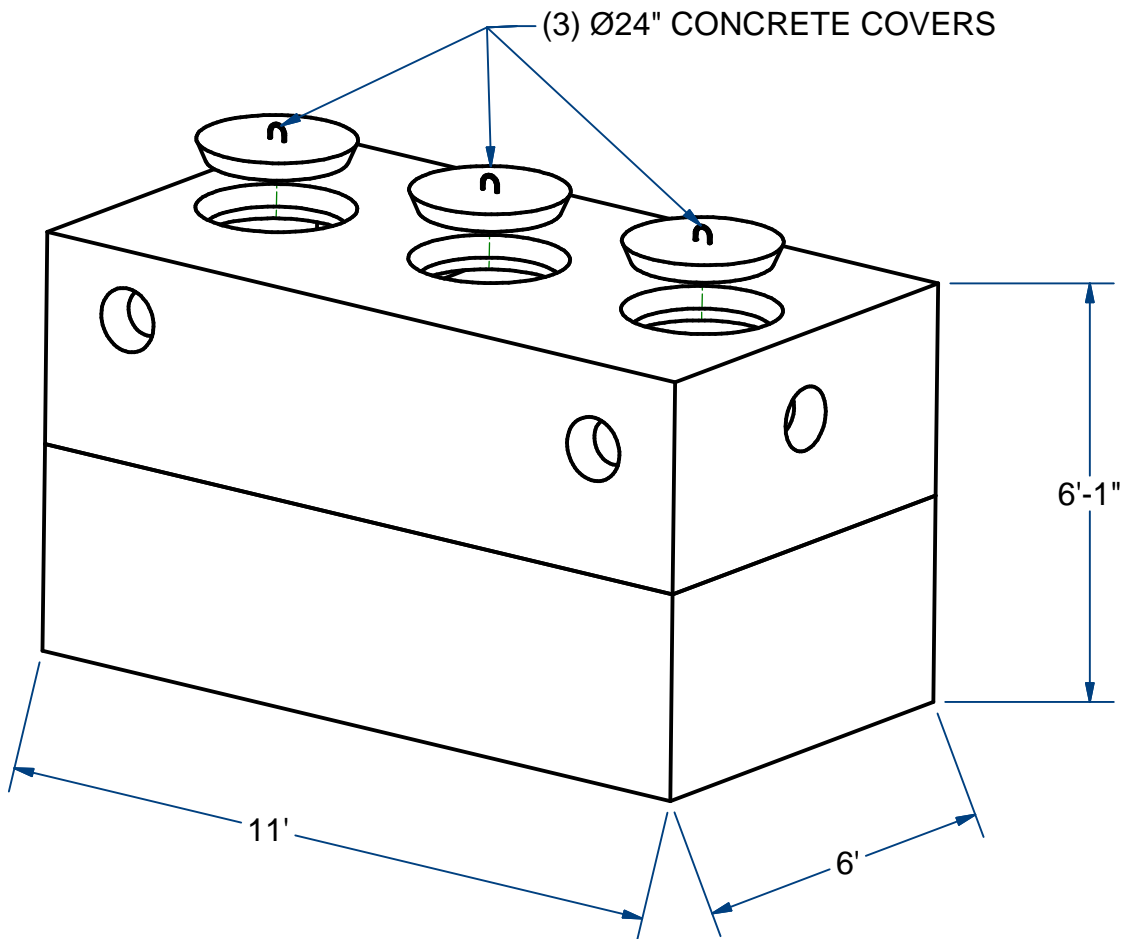

PUMP CHAMBER

H20

1500 Gallon

ACME-SHOREY

PRECAST CONCRETE PRODUCTS

NOTES:

- 1.) SEAM SEALED WITH FLEXIBLE BUTYL RUBBER SEALANT.

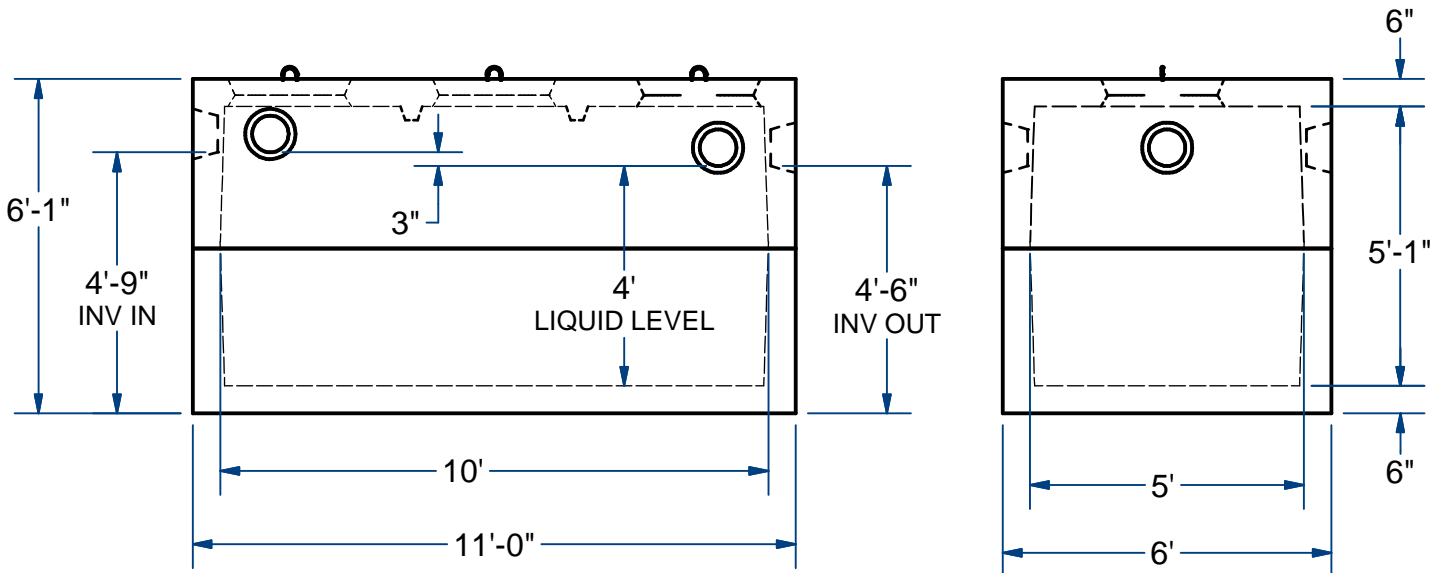
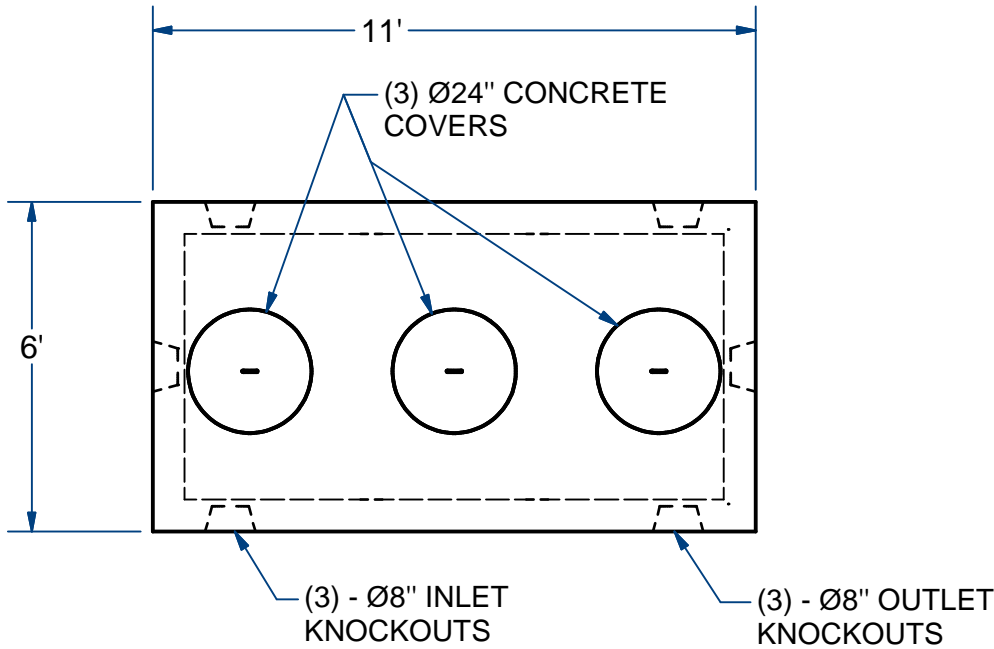

NAME: PUMP CHAMBER ,1500 Gallon

H-20

ITEM# PC152

Concrete Minimum Strength: 5,000 p.s.i. at 28 days
 Steel Reinforcement: ASTM A615, Grade 60
 Design Loading: standard units - AASHTO - H20

TOP 11,000 Lbs
 BOTTOM 12,000 Lbs

CH

DATE: 3-14-19

Ch 9 Pg 6.1 Sht 2 of 2