

NOTES:
1.) SEAM SEALED WITH FLEXIBLE BUTYL RUBBER SEALANT.

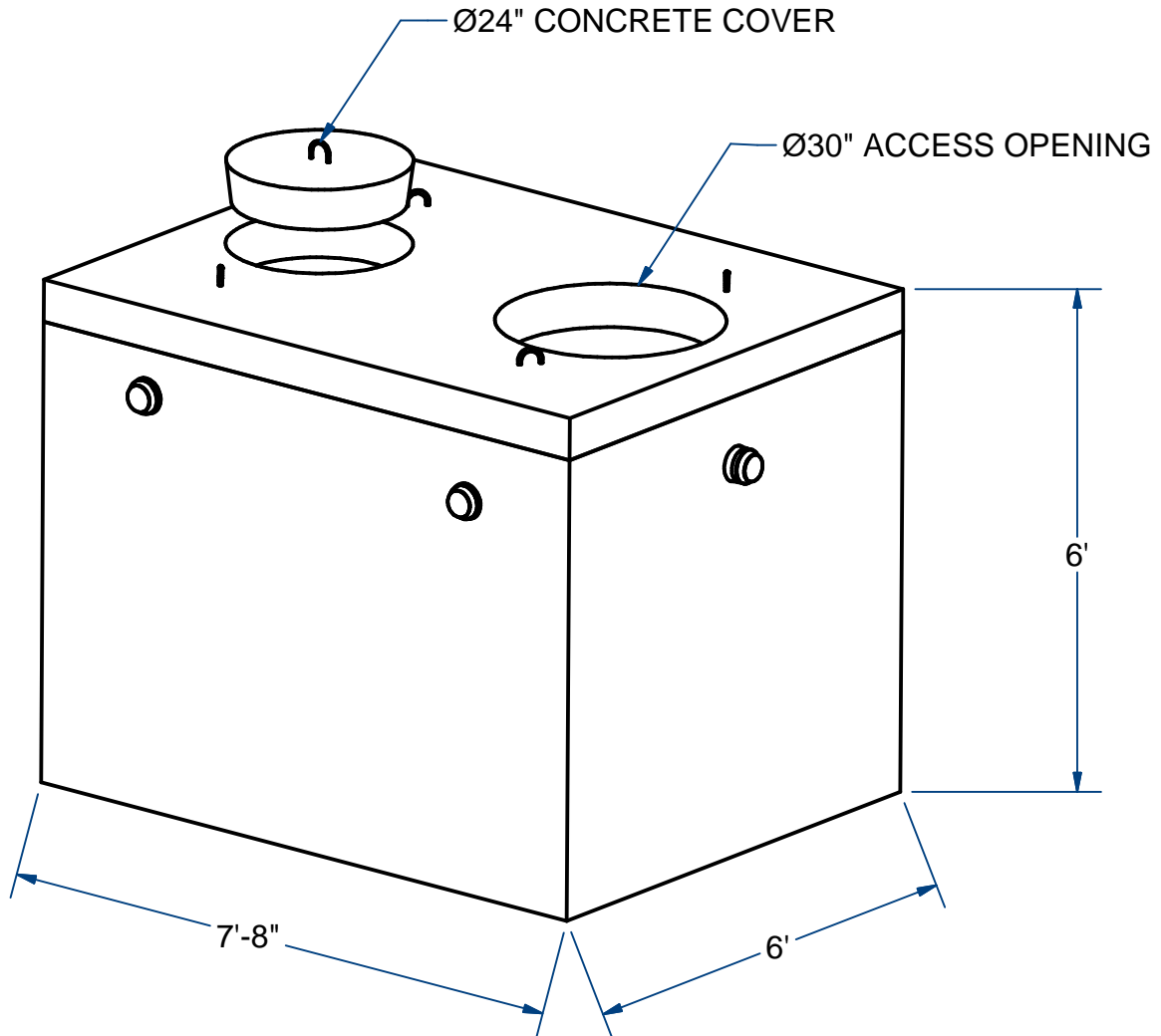

PUMP CHAMBER, Mono, W/BOOTS

H20

1,000 Gallon

ACME-SHOREY

PRECAST CONCRETE PRODUCTS

NOTES:

- 1.) SEAM SEALED WITH FLEXIBLE BUTYL RUBBER SEALANT.

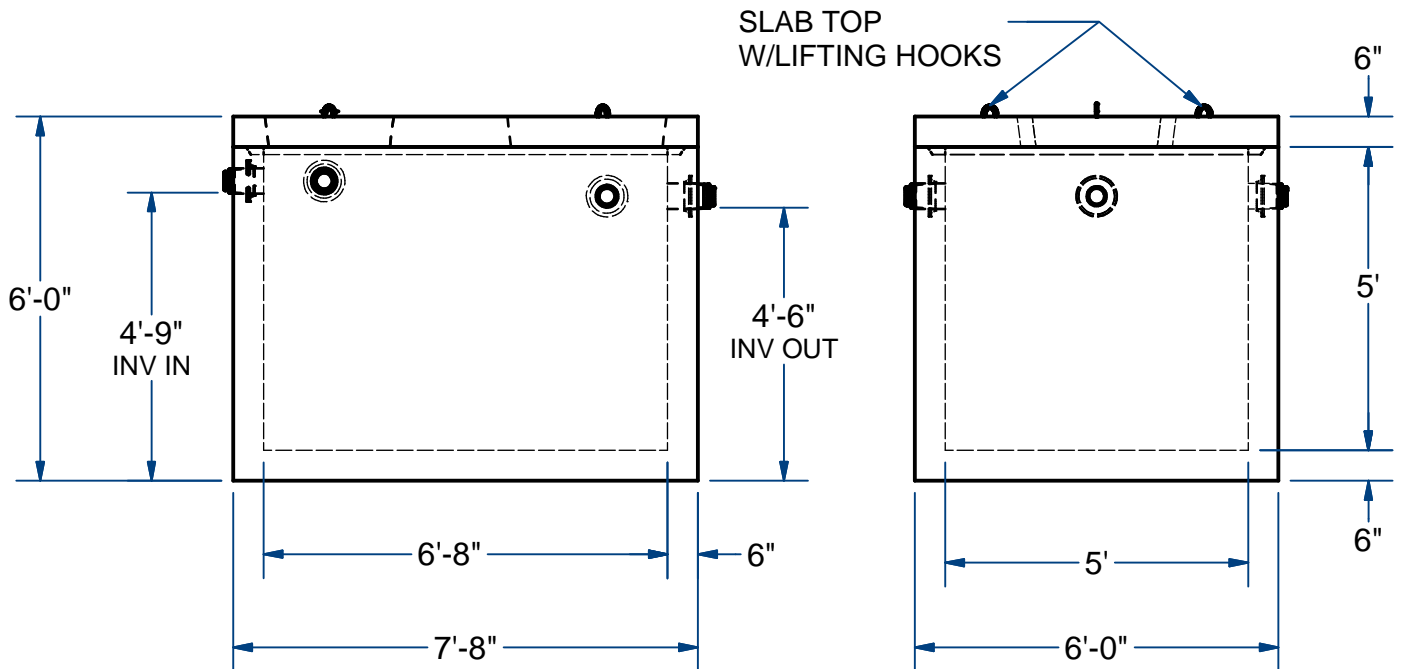
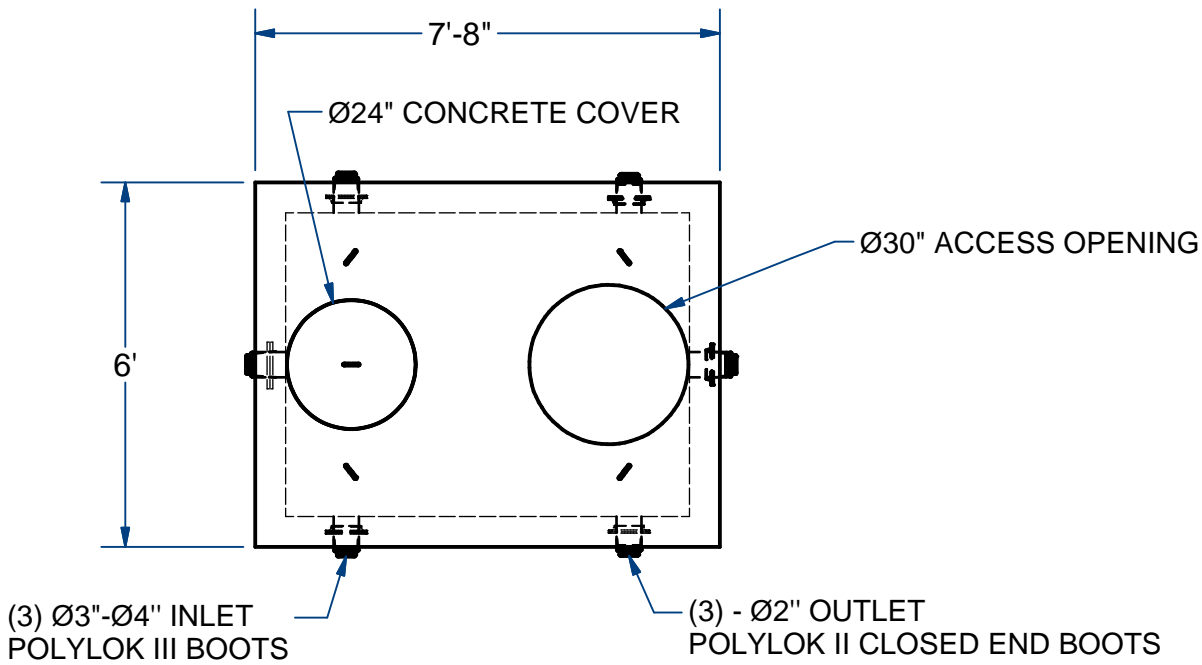

NAME: PUMP CHAMBER, 1000 Gallon, Mono, W/Boots
(W/ Ø30" ACCESS OPENING)

H-20

ITEM# PC102M30-B24

Concrete Minimum Strength: 5,000 p.s.i. at 28 days
Steel Reinforcement: ASTM A615, Grade 60
Design Loading: standard units - AASHTO - H20

TOP 3,100 Lbs
BOTTOM 13,400 Lbs

C

DATE: 2-3-2019

Ch 9 Pg 5.4 Sht 2 of 2