

NOTES:
1.) SEAM SEALED WITH FLEXIBLE BUTYL RUBBER SEALANT.

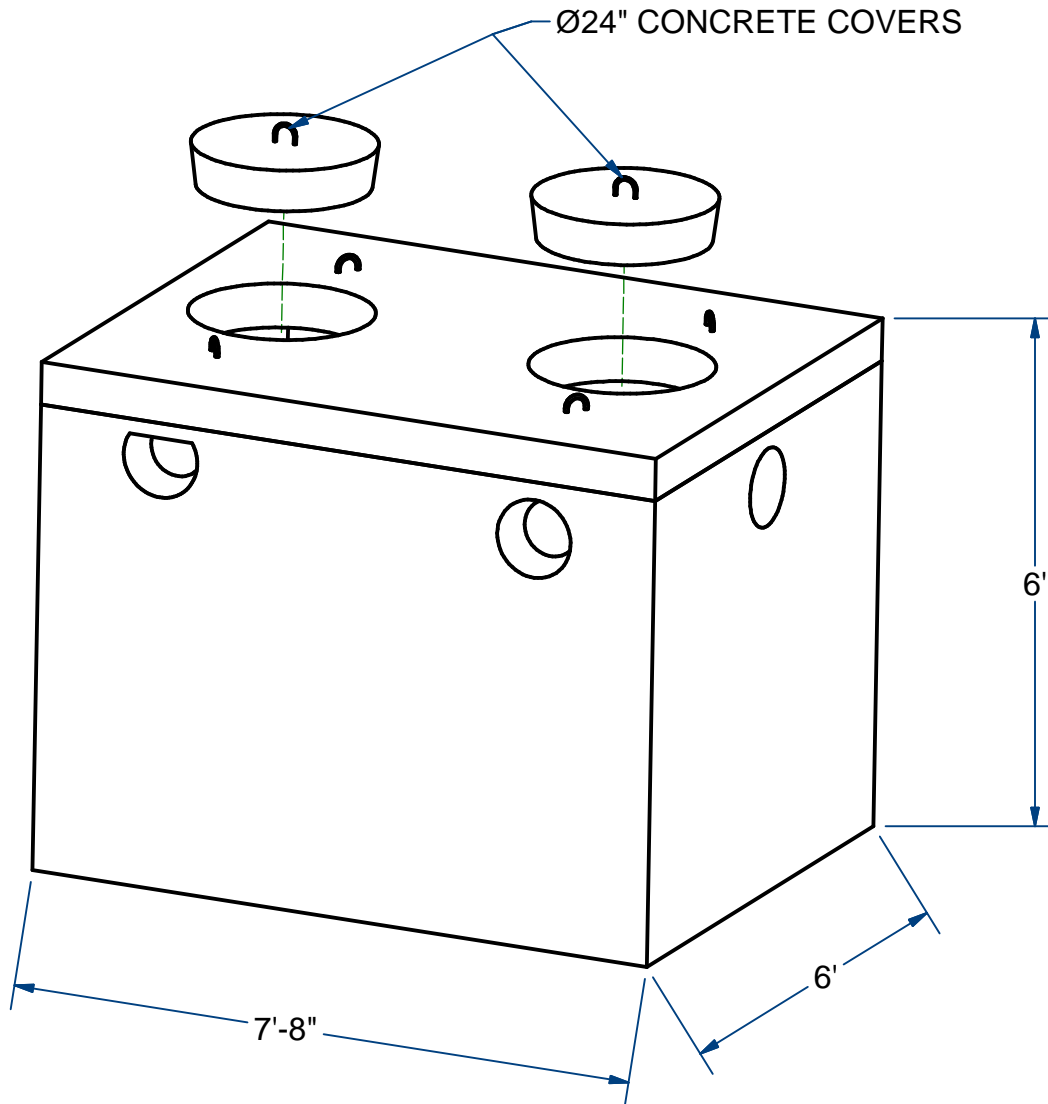

PUMP CHAMBER, MONO

H20

1,000 Gallon

ACME-SHOREY

PRECAST CONCRETE PRODUCTS

NOTES:

- 1.) SEAM SEALED WITH FLEXIBLE BUTYL RUBBER SEALANT.

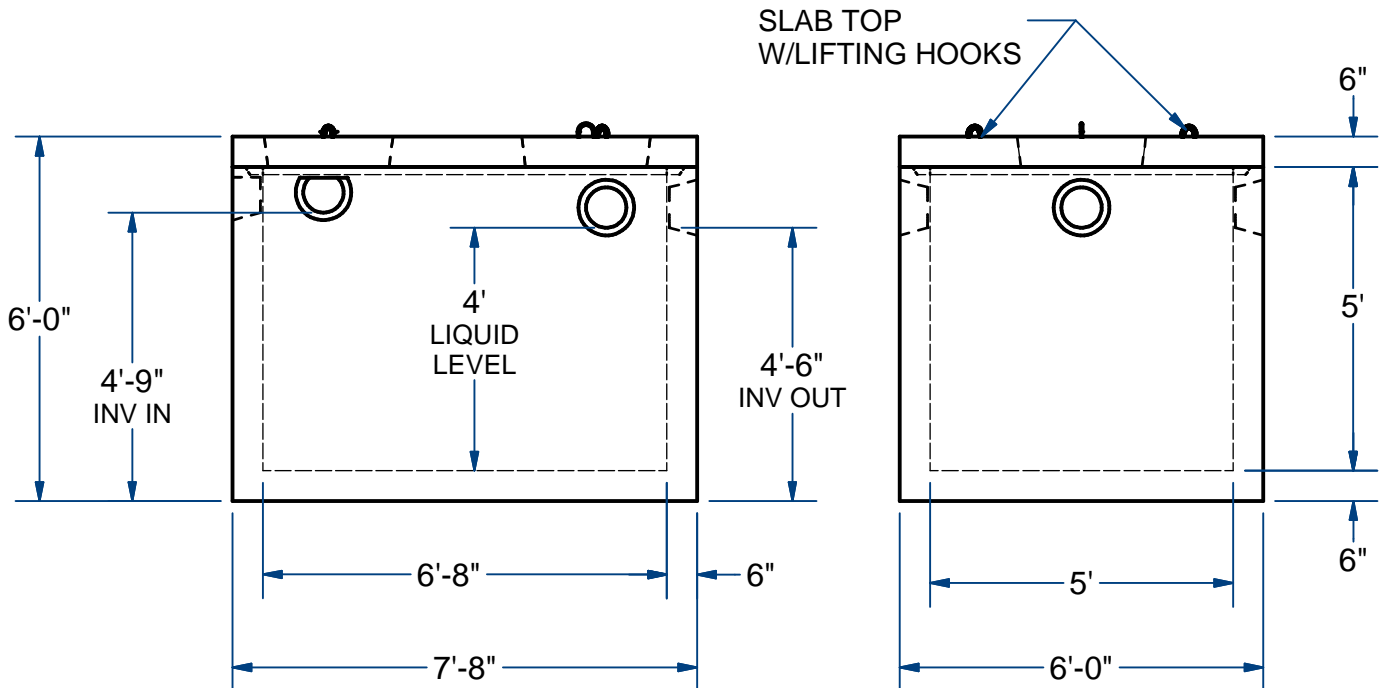
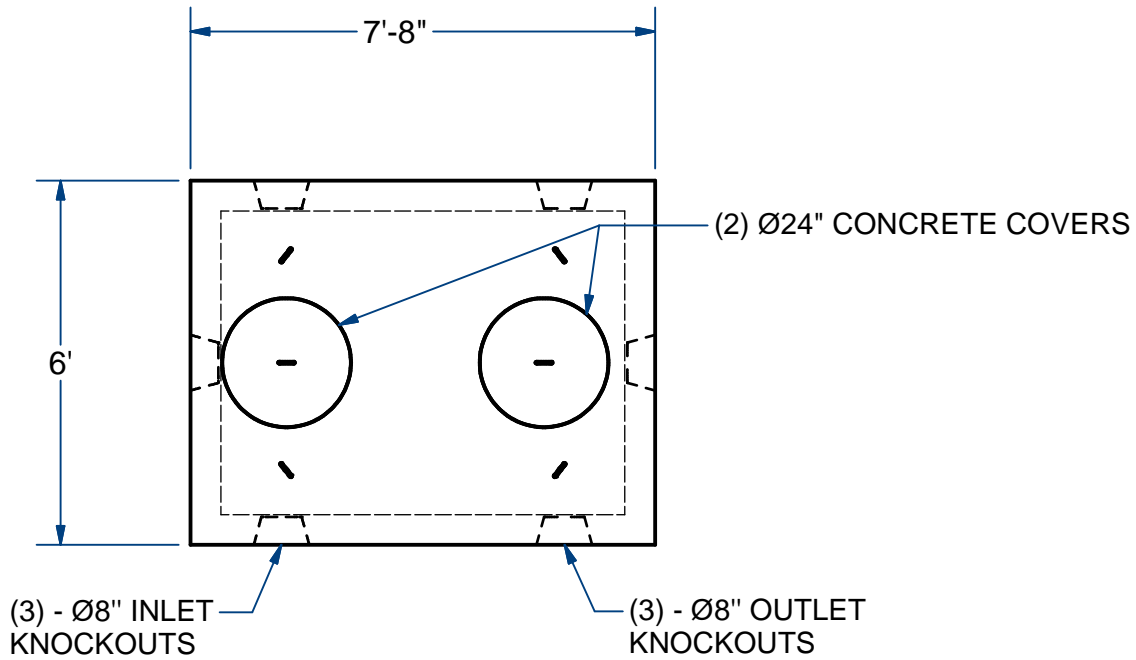

NAME: PUMP CHAMBER, 1000 Gallon, Mono

H-20

ITEM# PC102M

Concrete Minimum Strength: 5,000 p.s.i. at 28 days
 Steel Reinforcement: ASTM A615, Grade 60
 Design Loading: standard units - AASHTO - H20

TOP 3,100 Lbs
 BOTTOM 13,400 Lbs

A

DATE: 10-2-2018

Ch 9 Pg 5.1 Sht 2 of 2