

ACME-SHOREY

PRECAST CONCRETE PRODUCTS

WWW.ACMESHOREY.COM

PHONE (508) 548-9607

FAX (508) 548-1664

CARVER, MA
334 TREMONT STREET

HARWICH, MA
36 GREAT WESTERN ROAD

NOTES:

- 1.) GALVANIZED PULLING EYES AVAILABLE.
- 2.) OPTIONAL: MANHOLE FRAME & COVER.
(USES ERC285E)

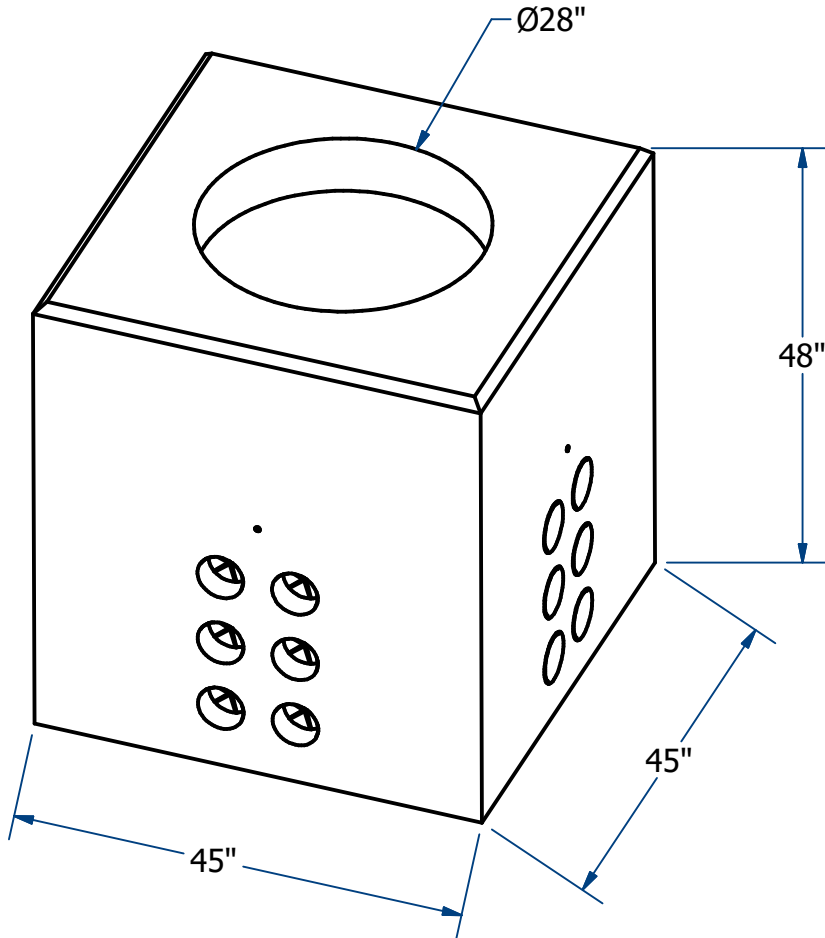

PRIMARY / SECONDARY PULL BOX FOUNDATION (NE-15) SINGLE PHASE

H10

ITEM# ENE15

Wt. 3,000 Lbs

23-4.2

Sht 1 of 2

ACME-SHOREY

PRECAST CONCRETE PRODUCTS

NOTES:

1.) GALVANIZED PULLING EYES AVAILABLE.

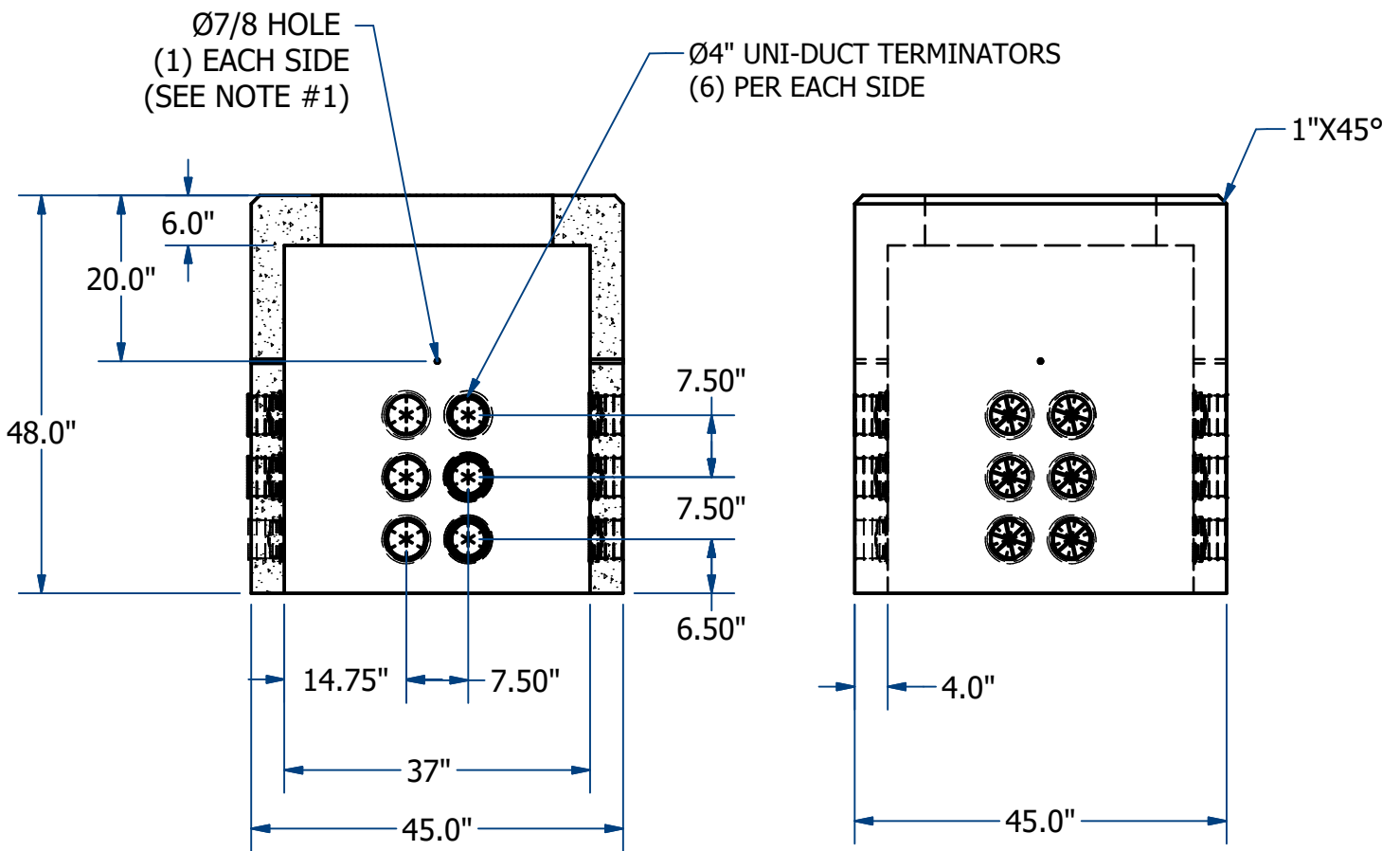
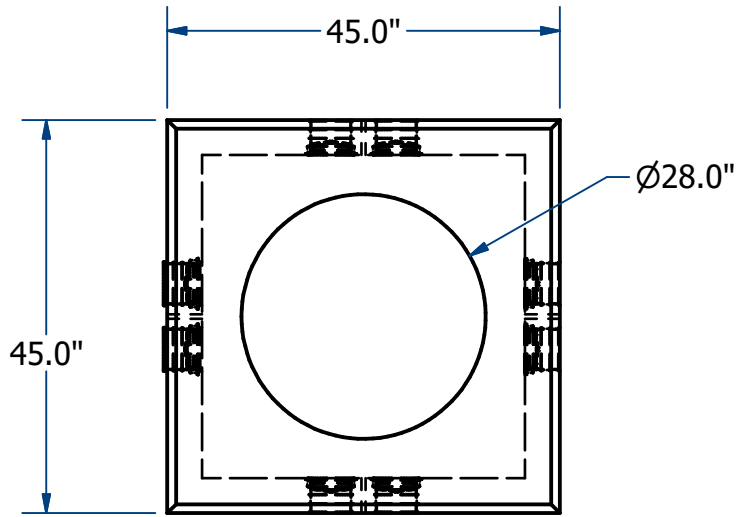

NAME: PULLBOX FOUNDATION (NE-15)
(PRIMARY / SECONDARY - SINGLE PHASE)

H10

ITEM# ENE15

Concrete Minimum Strength: 4,000 p.s.i. at 28 days
Steel Reinforcement: ASTM A615, Grade 60
Design Loading: standard units - AASHTO - H10

WEIGHT 3,000

Lbs

C

DATE: 10-5-21