

TRANSFORMER PAD FOUNDATION (NE-13)

THREE PHASE (150 KVA)

H20

ACME-SHOREY

PRECAST CONCRETE PRODUCTS

NOTES:

1.) REINFORCE TOP PAD TO H20 LOADS.

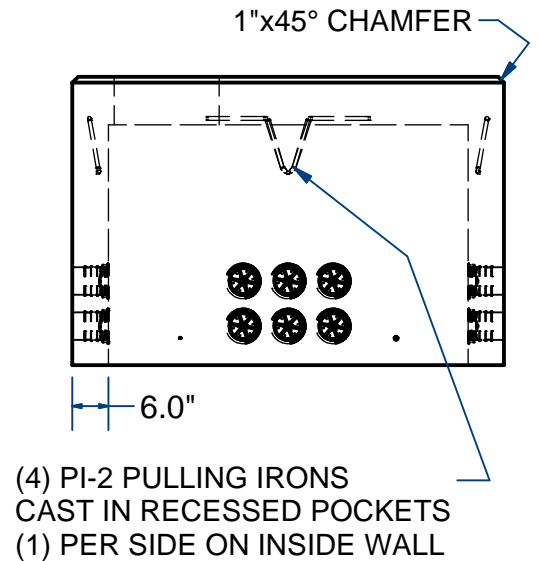
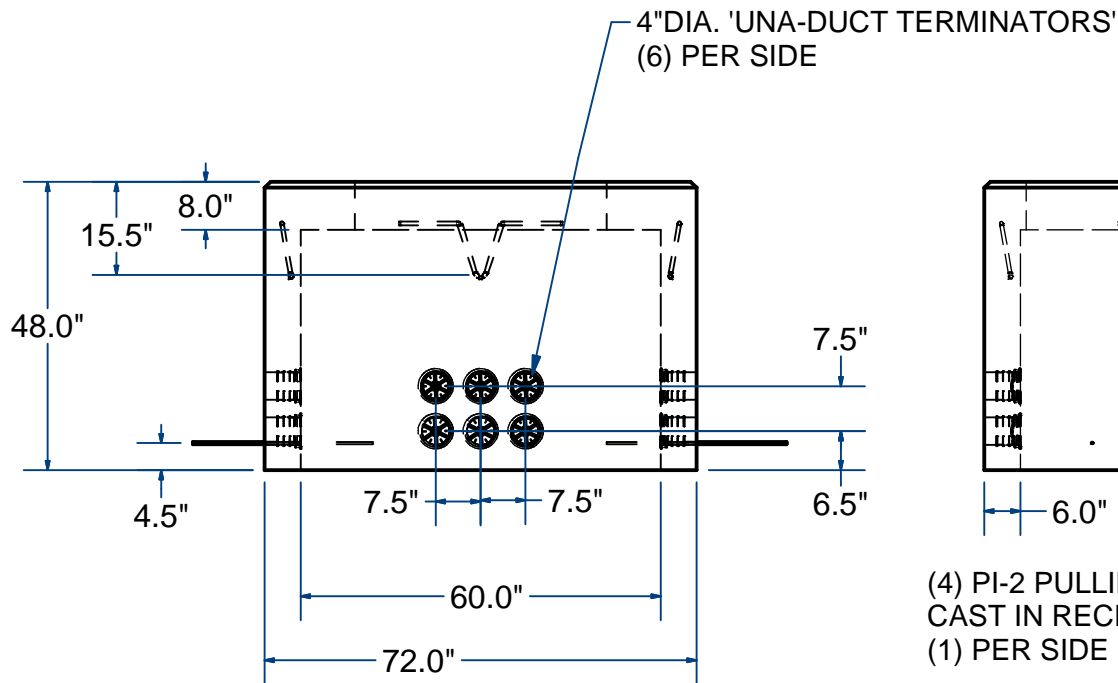
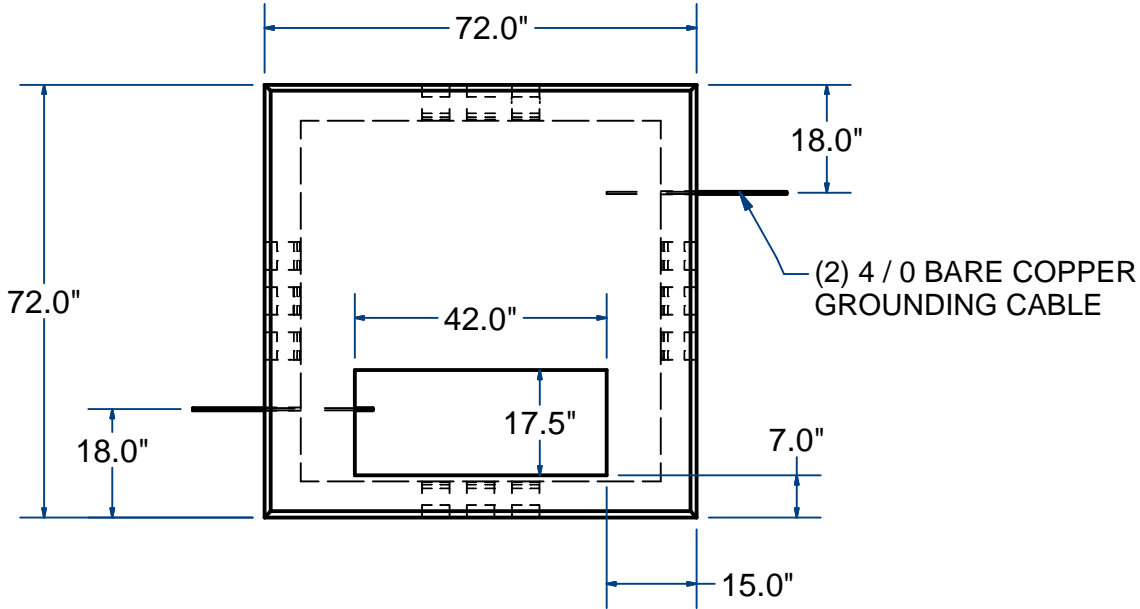

NAME: TRANSFORMER PAD FOUNDATION (NE-13)
(THREE PHASE - UP TO 150 KVA)

H-20

ITEM# ENE13

Concrete Minimum Strength: 5,000 p.s.i. at 28 days
Steel Reinforcement: ASTM A615, Grade 60
Design Loading: standard units - AASHTO - H20

WEIGHT 8,500

Lbs

C

DATE: 10-5-2021

Ch 23 Pg 5.1 Sht 2 of 2