

# ACME-SHOREY

PRECAST CONCRETE PRODUCTS

WWW.ACMESHOREY.COM

PHONE (508) 548-9607

FAX (508) 548-1664

CARVER, MA  
334 TREMONT STREET

HARWICH, MA  
36 GREAT WESTERN ROAD

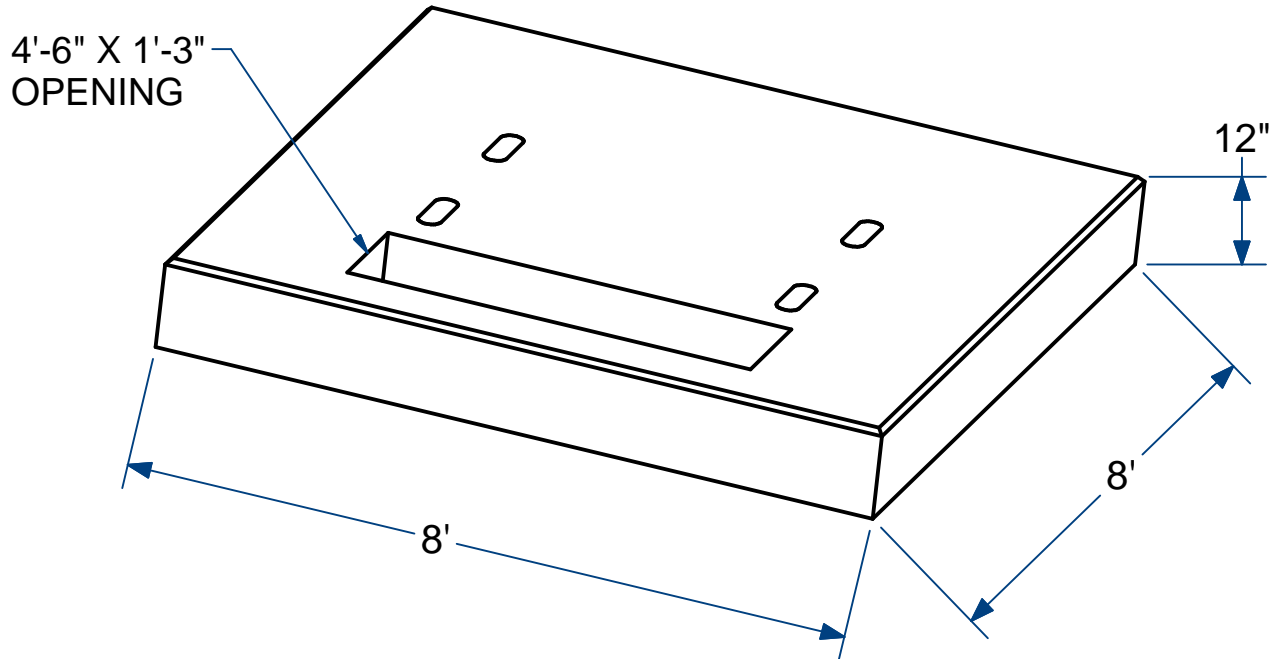

## TRANSFORMER PAD 8' X 8'

THREE PHASE  
(FOR TRANSFORMERS 500 UP TO 2,500 KVA)  
H20

ITEM# EM3801-2

Wt. 9,000 Lbs

23-5.3

Sht 1 of 2

# ACME-SHOREY

PRECAST CONCRETE PRODUCTS

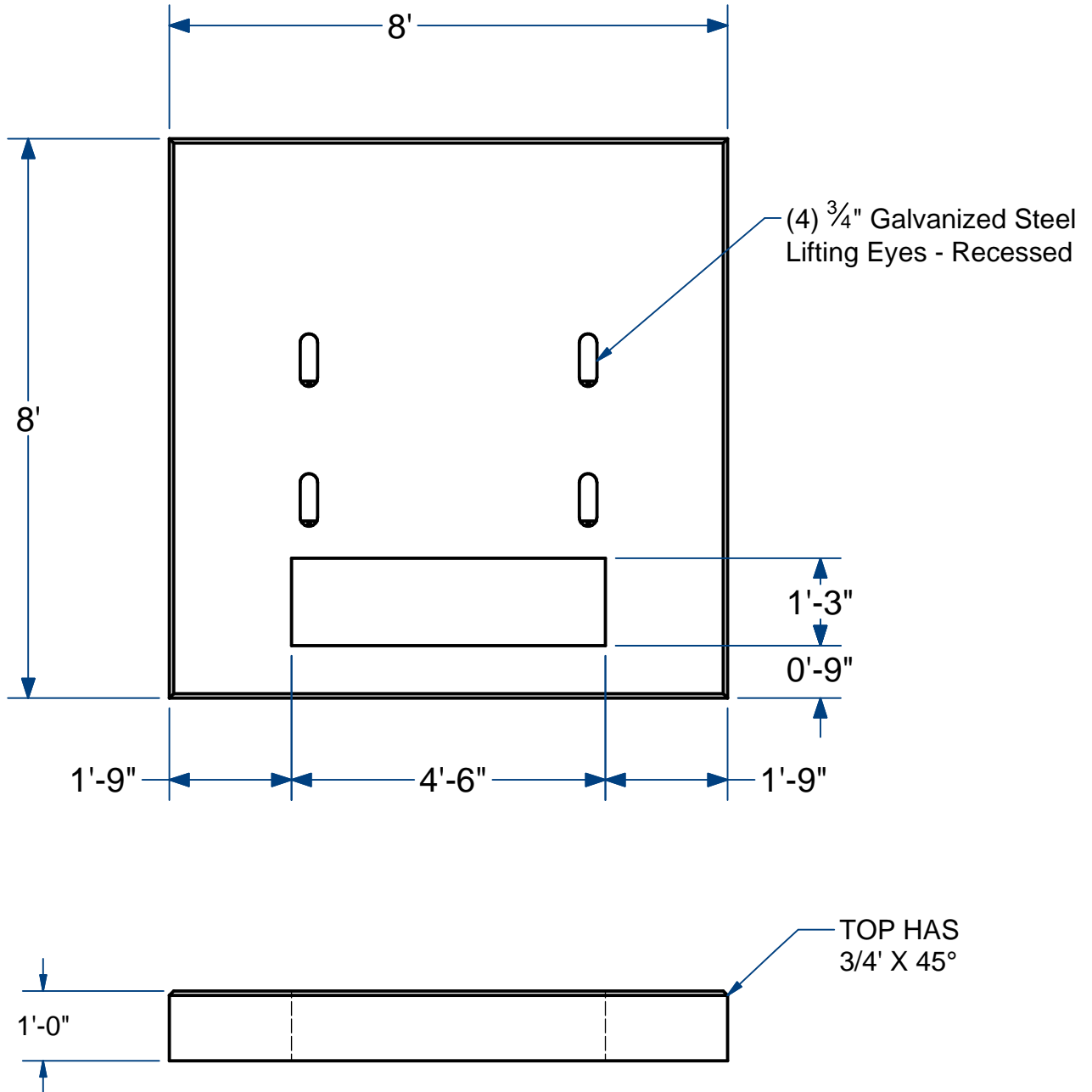

**NAME: PRECAST TRANSFORMER PAD**  
(THREE PHASE - (500 UP TO 2500 KVA))

**H-20**

**ITEM# EM3801-2**

Concrete Minimum Strength: 5,000 p.s.i. at 28 days  
Steel Reinforcement: ASTM A615, Grade 60  
Design Loading: standard units - AASHTO - H20

**WEIGHT 9,000 Lbs**

**C**

**DATE: 10-5-21**

Ch 23 Pg 5.3 Sht 2 of 2