

PRECAST CONCRETE RISERS - H10

ACME-SHOREY

PRECAST CONCRETE PRODUCTS

WWW.ACMESHOREY.COM

PHONE (508) 548-9607

FAX (508) 548-1664

CARVER, MA

334 TREMONT STREET

HARWICH, MA

36 GREAT WESTERN ROAD

Part#	Description-Risers H10	O.D.	Height 'C'	INV. 'G'	Lbs	Sct.	Co.
R18X06	Riser (18" id)	ø23"	6"	n/a	75	6 - 1	A
R18X08	Riser (18" id)	ø23"	8"	n/a	100	6 - 2	A
R18X12	Riser (18" id)	ø23"	12"	4"	150	6 - 3	A
R18X16	Riser (18" id)	ø23"	16"	5.5"	200	6 - 4	A
R18X24	Riser (18" id)	ø23"	24"	9.5"	300	6 - 5	A

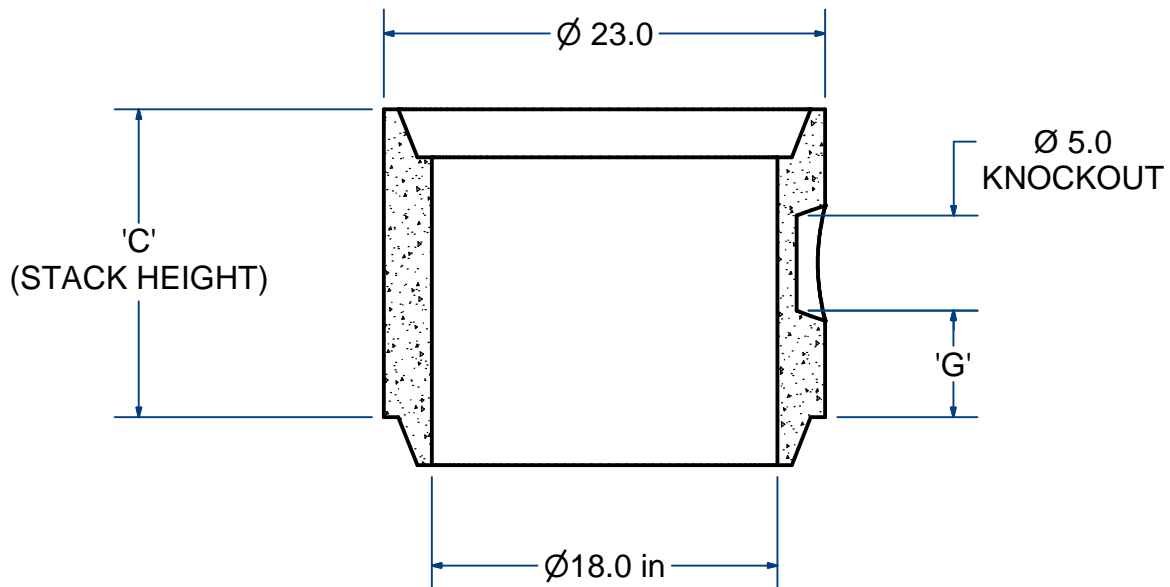
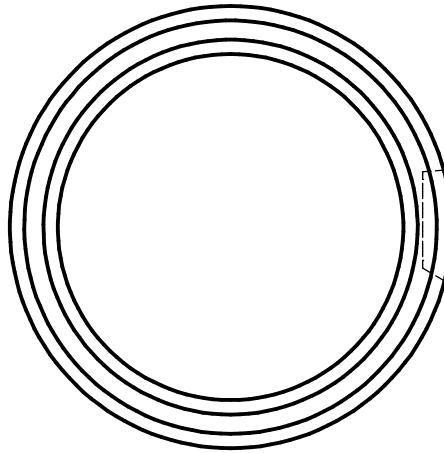

PRECAST CONCRETE RISERS - H10